



晶采光電科技股份有限公司  
AMPIRE CO., LTD.

## SPECIFICATIONS FOR LCD MODULE

<b>CUSTOMER</b>	
<b>CUSTOMER PART NO.</b>	
<b>AMPIRE PART NO.</b>	AG-240128ISTQW-30H-D(T)(R)
<b>APPROVED BY</b>	
<b>DATE</b>	

- Approved For Specifications
- Approved For Specifications & Sample

**AMPIRE CO., LTD.**  
**Building D., 2F., No.88, Sec. 1, Sintai 5th Rd., Sijhih City,**  
**Taipei County 221, Taiwan (R.O.C.)**  
台北縣汐止市新台五路一段 88 號 2 樓(東方科學園區 D 棟)  
**TEL:886-2-26967269 , FAX:886-2-86967196 or 26967270**

APPROVED BY	CHECKED BY	ORGANIZED BY

## RECORD OF REVISION

Revision Date	Page	Contents	Editor
2019/05/21	-	New Release	Mark

## 1 FEATURES

- (1) Display format : 240 × 128 dot-matrix ; 1/128 duty.
- (1) Construction : STN LCD, Bezel, Zebra ,Heat Seal, White LED back-light and PCB.
- (2) Display type : STN Negative, 6 o'clock view.
- (3) Built in controller RA6963.
- (4) 5V single power input. Built-in DC/DC converter for LCD driving.
- (5) Extended temperature type.
- (6) ROHS compliant.
- (7) New LED backlight

## 2 MECHANICAL DATA

Parameter	Stand Value	Unit
Dot size	0.40(W) × 0.40(H)	mm
Dot pitch	0.45(W) × 0.45(H)	mm
Viewing area	114.0(W) × 64.0(H)	mm
Module size (LED back-light)	150.0(W) × 104.0(H) × 15.5 max (T)	mm

## 3 ABSOLUTE MAXIMUM RATINGS

Parameter	Symbol	Min	Max	Unit
Logic Circuit Supply Voltage	VDD-VSS	0	7.0	V
LCD Driving Voltage	VDD-VO	0	26	V
Input Voltage	VI	VSS	VDD	V
Operating Temperature	TOP	-20	70	°C
Storage Temperature	Tstg	-30	80	°C

## 4 ELECTRICAL CHARACTERISTICS

Parameter	Symbol	Condition	Min	Typ	Max	Unit	Note
----- Electronic Characteristics -----							
Logic Circuit Supply Voltage	VDD-VSS	--	4.75	5.0	5.25	V	
LCD Driving Voltage	VDD-VO	-20 °C	17.9	18.8	19.7	V	-20 ~ 70 °C for Extended Temp. type
		0 °C	17.6	18.5	19.4		
		25 °C	17.3	18.2	19.1		
		50 °C	16.9	17.8	18.7		
		70 °C	16.5	17.4	18.3		
Input Voltage	VIH	--	0.7 VDD	--	VDD	V	
	VIL	--	VSS	--	0.3 VDD	V	
Logic Supply Current	IDD	VDD = 5V	--	25	--	mA	
----- Optical Characteristics -----							
Contrast	CR	STN type	--	5	--		Note 1
Rise Time	tr	25°C	--	117	--	ms	Note 2
Fall Time	tf	25°C	--	139	--	ms	
Viewing Angle Range	$\theta f$	25°C & CR $\geq$ 2	--	32	--	Deg.	Note 3
	$\theta b$		--	28	--		
	$\theta l$		--	30	--		
	$\theta r$		--	30	--		
Frame Frequency	fF	25°C	--	64	--	Hz	

(NOTE 1) Contrast ratio :

CR = (Brightness in ON state) / (Brightness in OFF state)

( NOTE 2 ) Response time :

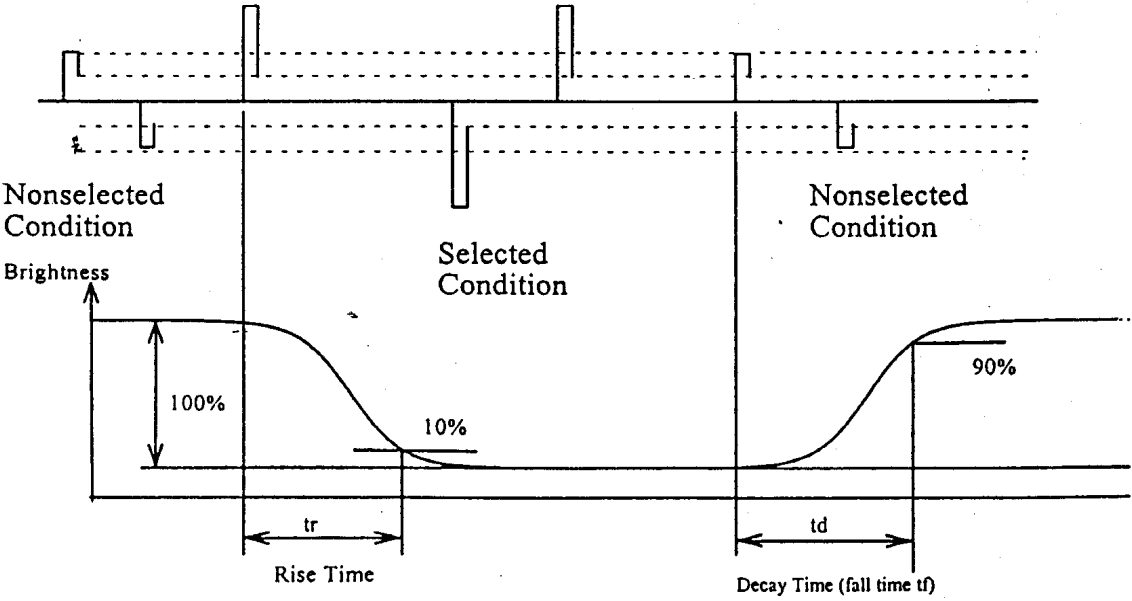

(NOTE 3) Viewing angle

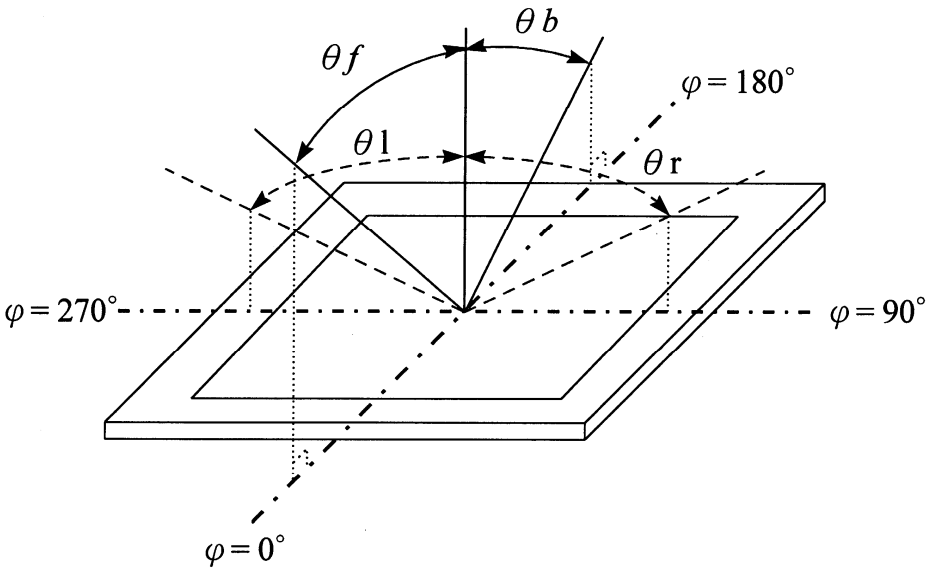

#### 4.1 White edge-type LED Back-Light SPECIFICATION

----- White LED Back-light Characteristics -----							
Parameter	Symbol	Condition	Min	Typ	Max	Unit	Note
Forward Current	IF		--	90	120	mA	Note 4 & 7
LCM Luminous intensity (Full White pattern)		IF=90mA	--	20	--	cd/m <sup>2</sup>	Note 4
Forward Voltage	VF	IF=90mA	--	3.2	3.5	V	Note 5
LED C.I.E	X	IF=90mA	0.26	0.30	0.34		Note 6
	Y	IF=90mA	0.27	0.31	0.35		

Note 4: Luminous intensity is decided by forward current of White LED.

Note 5: White LEDs are with voltage tolerance.

Note 6: White LEDs are with color tolerance.

\* LED Dice number = 6



Note 7 : One LED Current Diagram

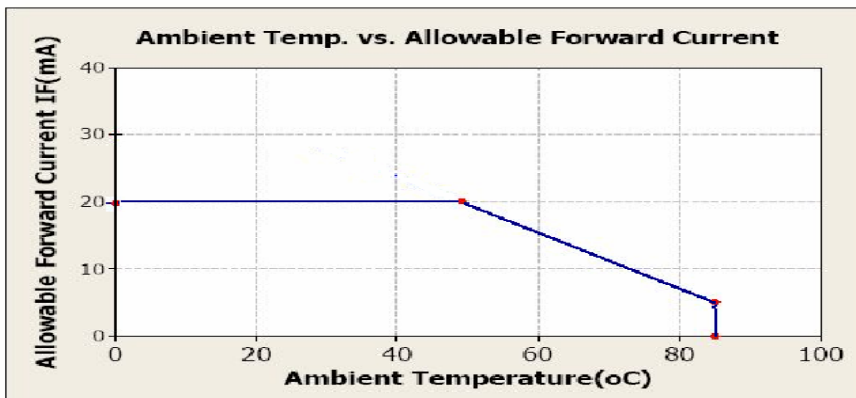

## 5 TIMING CHARACTERISTICS

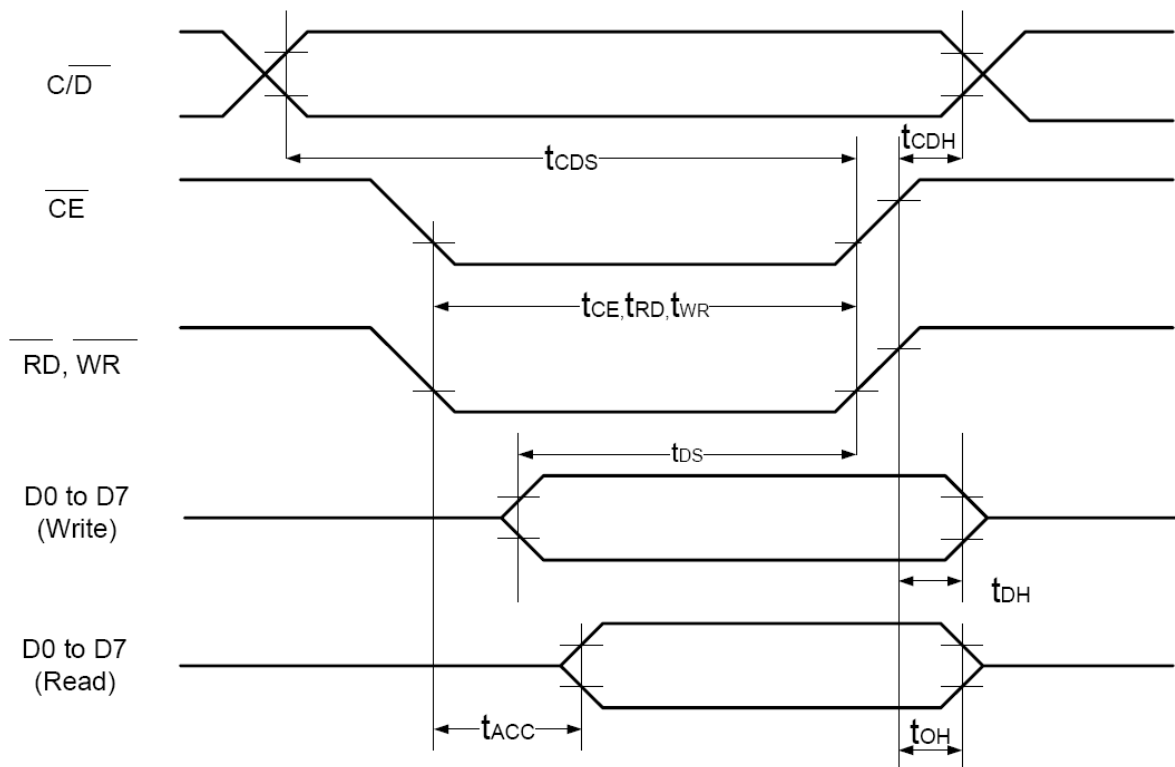

ITEM	SYMBOL	MIN	MAX	UNIT
C/D SET UP TIME	TCDS	100	--	ns
C/D HOLD TIME	THCL	10	--	ns
/CE,/RD,/WR PULSE WIDTH	TCE,TRD,TWR	80	--	ns
DATA SET UP TIME	TDS	80	--	ns
DATA HOLD TIME	TDH	40	--	ns
ACCESS TIME	TACC	--	150	ns
OUTPUT HOLD TIME	TOH	10	50	ns

## 6 BLOCK DIAGRAM & INTERFACE

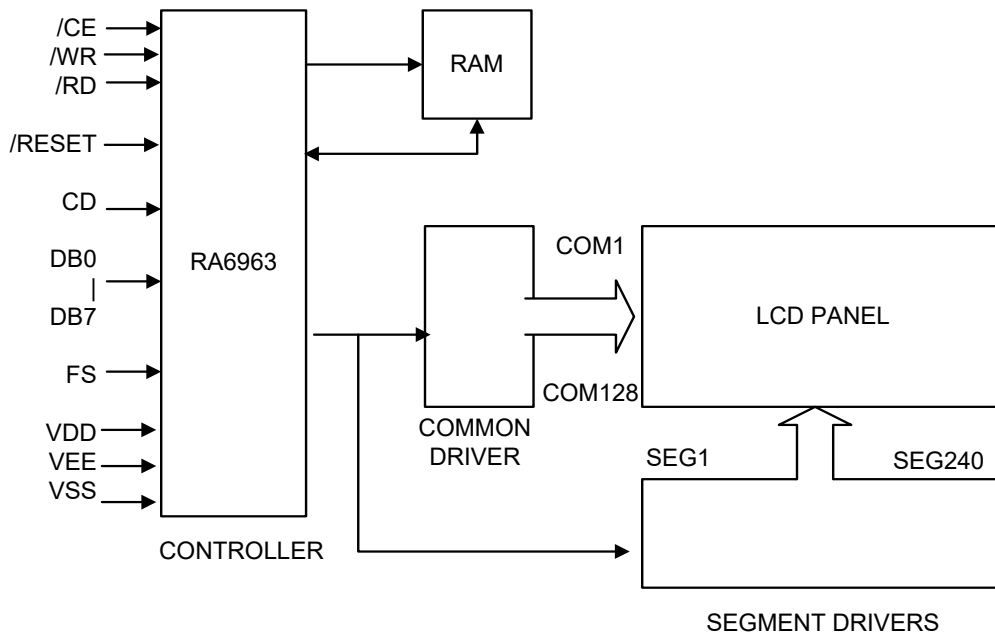

Pin No.	Symbol	Function
1	VSS	Ground (0V)
2	VDD	Logic Supply Voltage(+5V)
3	VO	Contrast Adjustment
4	C/D	WR = L --- C/D = H : Command Write    C/D = L : Data Write RD = L --- C/D = H : Status Read        C/D = L : Data Read
5	/RD	Read data when RD = L
6	/WR	Write data when WR = L
7-14	DB0 - DB7	Data Bus Line
15	/CE	Chip Enable
16	/RES	H --- Normal    L --- Initialize RA6963
17	VEE	Negative Power Supply (-20V)
18	MD2	Pin for selection of number of columns H – 32 columns    L – 40 columns
19	FS	FS : Pin for selection of font    H -- Font 6x8 (default) L -- Font 8x8
20	NC	No Connection



7 POWER SUPPLY

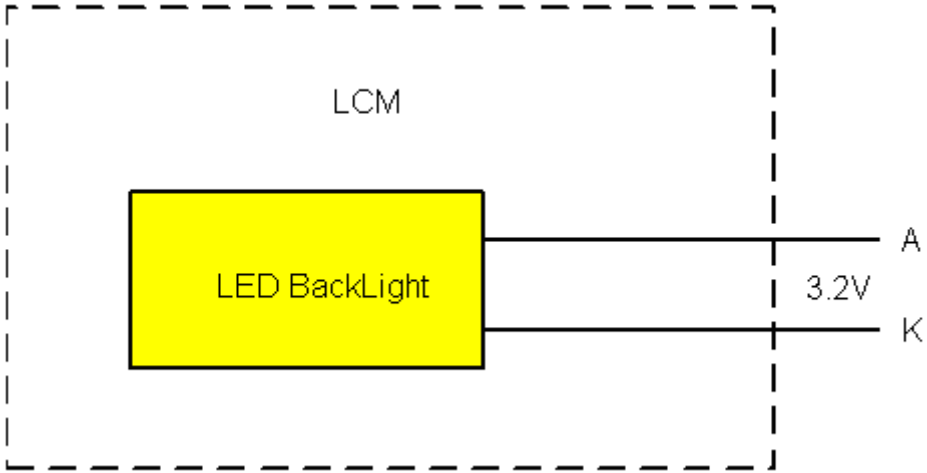
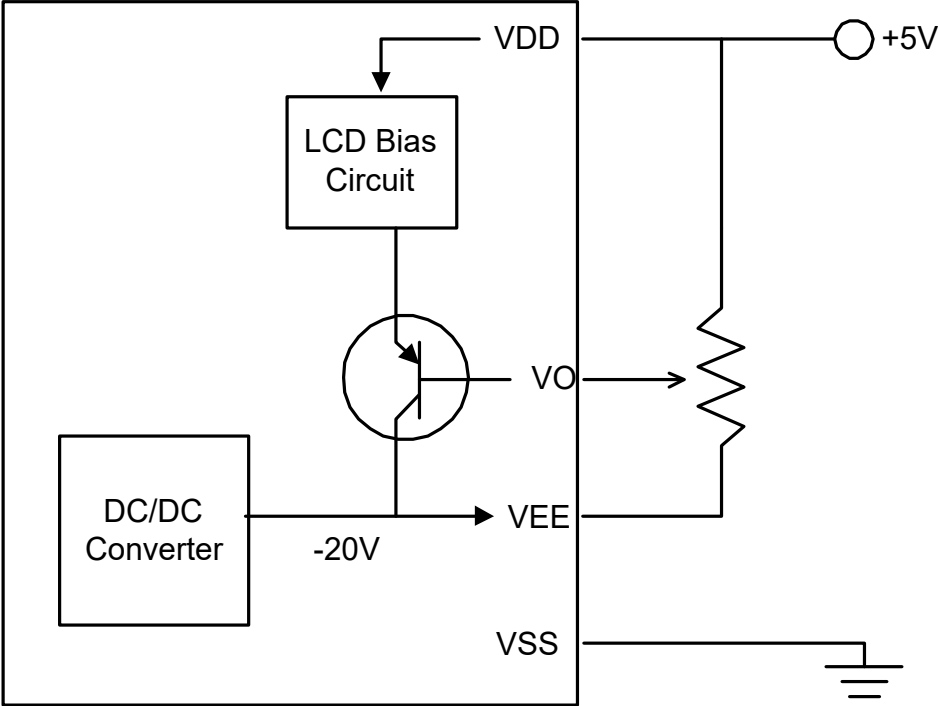

## **8 QUALITY AND RELIABILITY**

### **8.1 TEST CONDITIONS**

Tests should be conducted under the following conditions :

Ambient temperature :  $25 \pm 5^{\circ}\text{C}$

Humidity :  $60 \pm 25\% \text{ RH}$ .

### **8.2 SAMPLING PLAN**

Sampling method shall be in accordance with MIL-STD-105E, inspection level II, normal inspection, and single sampling plan tables for normal, tightened, and reduced inspection.

### **8.3 ACCEPTABLE QUALITY LEVEL**

A major defect is defined as one that could cause failure to or materially reduce the usability of the unit for its intended purpose. A minor defect is one that does not materially reduce the usability of the unit for its intended purpose or is an infringement from established standards and has no significant bearing on its effective use or operation.

### **8.4 APPEARANCE**

An appearance test should be conducted by human sight at approximately 30 cm distance from the LCD module under fluorescent light. The inspection area of LCD panel shall be within the range of following limits.

## 8.5 INSPECTION QUALITY CRITERIA

ITEM	Description of defects			Class of defects	remark
Function	No display		Reject	Major	
	Display abnormal		Reject	Major	
	Missing line		Reject	Major	
Black spots	Ave. dia. D		Area A	Area B	Minor Two spots must be between about 5 mm
	$D \leq 0.13$		Disregard		
	$0.13 < D \leq 0.15$		2	2	
	$0.13 < D \leq 0.25$		1	2	
	$0.25 < D$		0	1	
Black line	Width W	Length L	Area A	Area B	Minor
	$\leq 3.0$	$\leq 0.02$	Disregard		
	$\leq 2.0$	$\leq 0.04$	2	2	
	$\leq 1.0$	$\leq 0.06$	1	2	
		$> 0.06$	0	0	
Scratch	Width W		Length L	Accept	Minor
	$W \leq 0.02$		-----	Disregard	
	$0.02 \leq W \leq 0.05$		$L \leq 3.0$	2	
	$W > 0.05$		-----	0	
Appearance	PCB copper circuit showed		Reject		Minor
	PCB scratch was over 5 mm		Reject		
	Sort pad was damaged		Reject		
★ Back-Light	Function didn't work		Reject		Major
	Some area didn't work		Reject		
	Bright was not even		Reject		
	B/L color was not correct		Reject		

『★』 Symbol means LCM has this material.

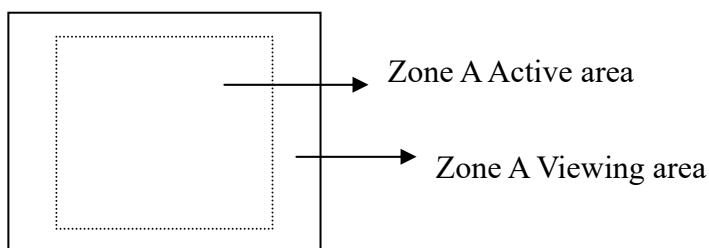

## 8.6 RELIABILITY

Test Item	Test Conditions	Note
	Extended Temp. type	
High Temperature Operation	70±3°C , t=96 hrs	
Low Temperature Operation	-20±3°C , t=96 hrs	
High Temperature Storage	80±3°C , t=96 hrs	1,2
Low Temperature Storage	-30±3°C , t=96 hrs	1,2
Thermal Shock Test	-30°C ~ 25°C ~ 80°C 30 min. 5 min. 30 min. ( 1 cycle ) Total 5 cycle	1,2
Humidity Test	40 °C, Humidity 90%, 96 hrs	1,2
Vibration Test (Packing)	Sweep frequency : 10 ~ 55 ~ 10 Hz/1min Amplitude : 0.75mm Test direction : X.Y.Z/3 axis Duration : 30min/each axis	2

Note 1 : Condensation of water is not permitted on the module.

Note 2 : The module should be inspected after 1 hour storage in normal conditions (15-35°C , 45-65%RH).

Note 3 : The module shouldn't be tested more than one condition, and all the test conditions are independent.

Note 4 : All the reliability tests should be done without protective film on the module.

## 9 HANDLING PRECAUTIONS

- (1) A LCD module is a fragile item and should not be subjected to strong mechanical shocks.
- (2) Avoid applying pressure to the module surface. This will distort the glass and cause a change in color.
- (3) Under no circumstances should the position of the bezel tabs or their shape be modified.
- (4) Do not modify the display PCB in either shape or positioning of components.
- (5) Do not modify or move location of the zebra or heat seal connectors.
- (6) The device should only be soldered to during interfacing. Modification to other areas of the board should not be carried out.
- (7) In the event of LCD breakage and resultant leakage of fluid do not inhale, ingest or make contact with the skin. If contact is made rinse immediately.
- (8) When cleaning the module use a soft damp cloth with a mild solvent, such as Isopropyl or Ethyl alcohol. The use of water, ketone or aromatic is not permitted.
- (9) Prior to initial power up input signals should not be applied.
- (10) Protect the module against static electricity and observe appropriate anti-static precautions.
- (11) AMIPRE will provide one year warranty for all products and three months warrantee for all repairing products.

